

Universal Rail Pump Shotgun & SC-5 Gun Rack SC-920-D-1-5

Components:

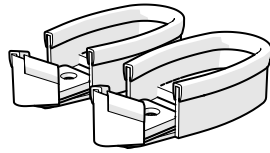

2xSC-1900 Butt Plate

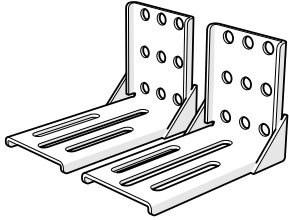

2xSC-9903 L-Bracket

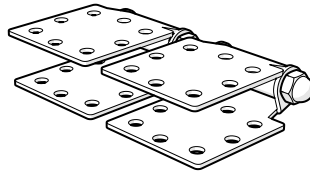

2xSC-9302 Mounting Hinge

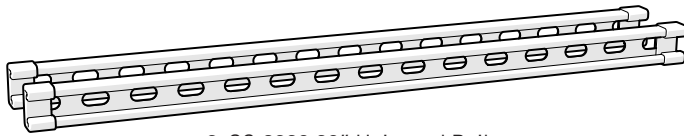

2xSC-9230 30" Universal Rail



8xSC-5301 Universal Rail Nuts



14xSC-8002 Allen Head Bolt



6xSC-8005 Flat Washers



6xSC-8003 Nuts



6xSC-8004 Lock Washers

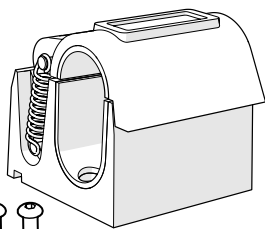

1xSC-1 Gun lock

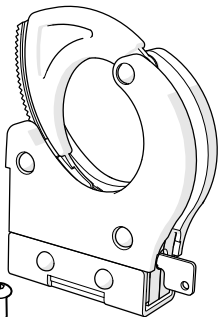

1xSC-6 Gun lock

Comment: Various weapons can be installed on any side.
Warning: During installation continuously monitor correct position and direction of the components.

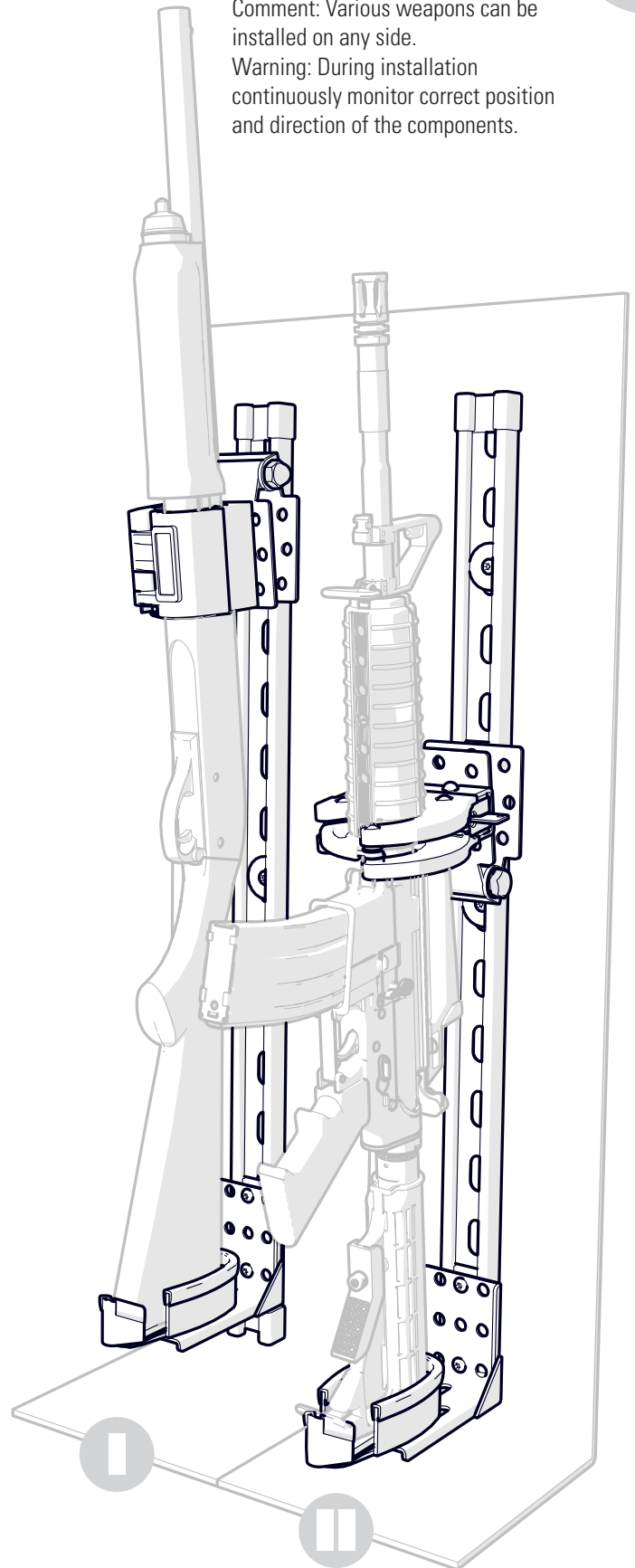

Universal Rail Pump Shotgun & SC-5 Gun Rack SC-920-D-1-5

Exploded view:

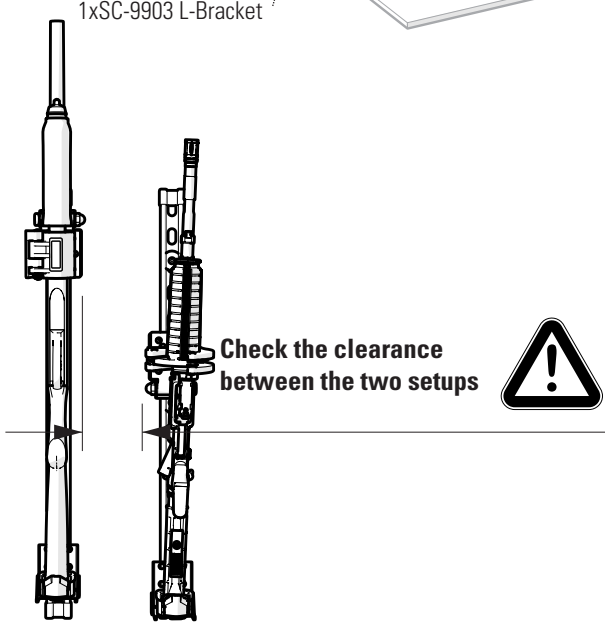
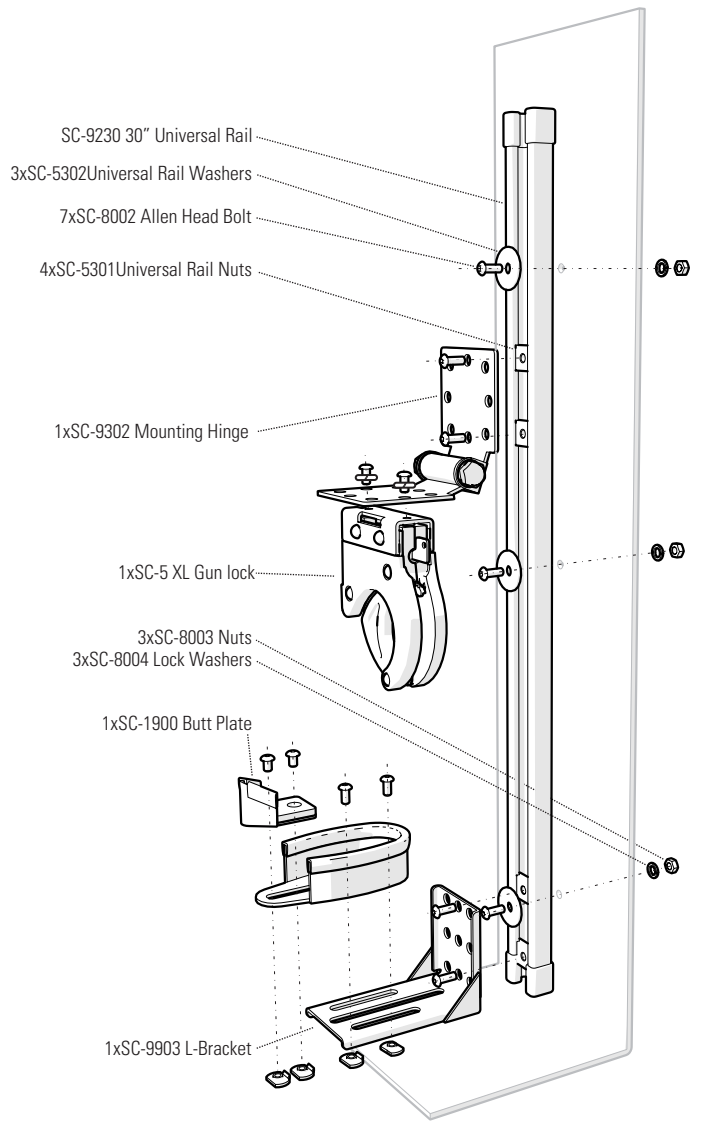
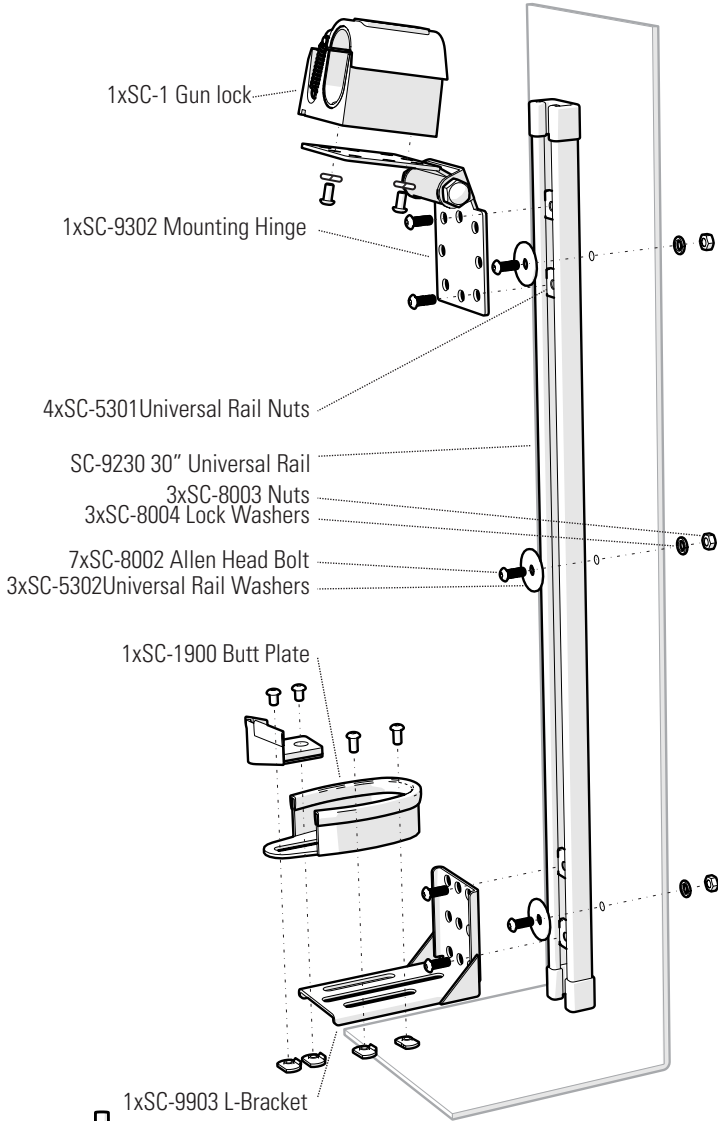

Check the clearance between the two setups





Universal Rail Pump Shotgun & SC-5 Gun Rack

1 Install Gun Lock

Install SC-1 onto hinge (A) (part No. SC-9302) and install the hinge (including SC-1) onto 30" Universal Rail (B) (part No.: SC-9230).

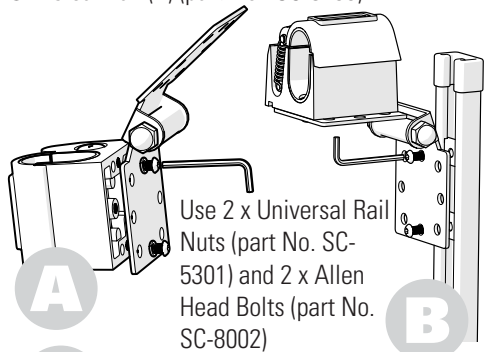

Use 2 x Universal Rail Nuts (part No. SC-5301) and 2 x Allen Head Bolts (part No. SC-8002)

2 Install Butt Plate

Install L-bracket onto 30" Universal Rail (part No. SC-9230)

Use 2 x Universal Rail Nuts (part No. SC-5301) and 2 x Allen Head Bolts (part No. SC-8002)

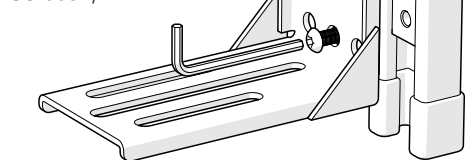

Install Butt Plate (No. SC-1900) on L-bracket (part No. SC-9903) as illustrated, using allen screws and metal screws provided with the butt plate.

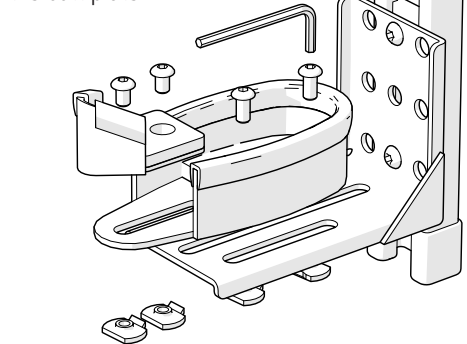

3 Adjust the parts

Slightly tighten all bolts and screws so you can still move parts around. Put your actual weapon in the gun lock and butt plate and position your whole assembly at your intended location. Adjust hinge height/angle and butt plate position until your weapon is properly lined up.

Parts of the weapon may interfere with parts of Mounting Hinge (No. SC-9302). In this case turn the hinge around 180 degrees.

Warning: Weapon must have some (1/16") free play in gun lock for gun lock mechanism to operate correctly. Weapon should not press against gun lock door.

4 Mark the holes

Mark screw locations on wall/floor. Check back side of wall for fuel or electric lines.

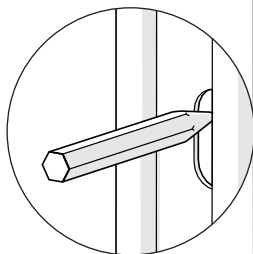

5 Drill and install

Drill your holes and install assembly.

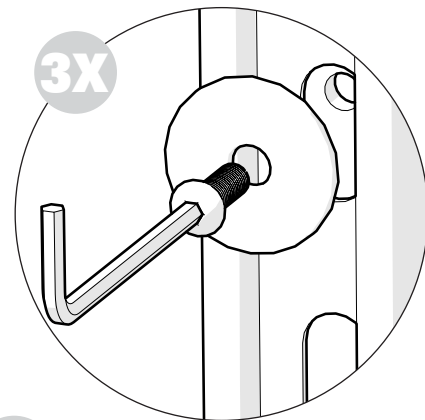

6 Tighten the screws

Place your weapon in the setup, test and retest your installation by repeatedly inserting and removing the weapon from the assembly. When satisfied, tighten all screws and test again.

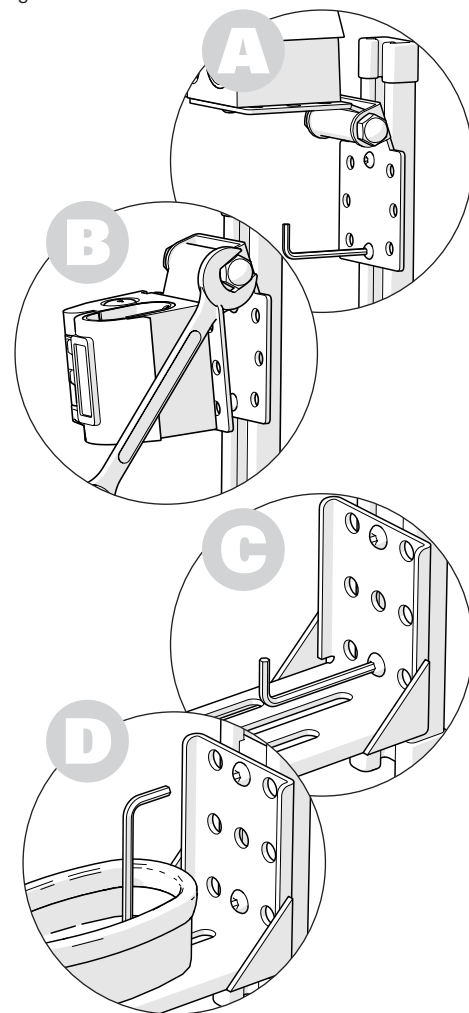

How to use the SC-5301 Universal Rail Nuts

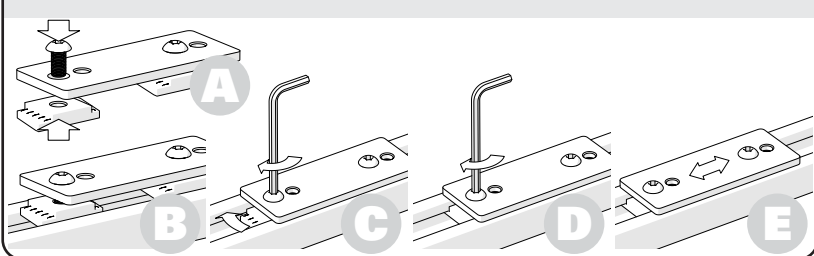



Universal Rail Pump Shotgun & SC-5 Gun Rack SC-920-D-1-5

1 Install Gun Lock

Install gun lock SC-6 onto hinge (A) (part No. SC-9302). Install the hinge on 30" Universal Rail (B) (part No.: SC-9230).

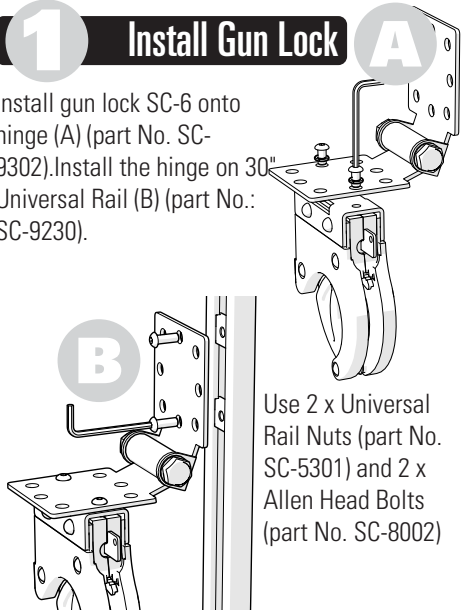

Use 2 x Universal Rail Nuts (part No. SC-5301) and 2 x Allen Head Bolts (part No. SC-8002)

2 Install Butt Plate

Install L-bracket onto 30" Universal Rail (part No. SC-9230)

Use 2 x Universal Rail Nuts (part No. SC-5301) and 2 x Allen Head Bolts (part No. SC-8002)

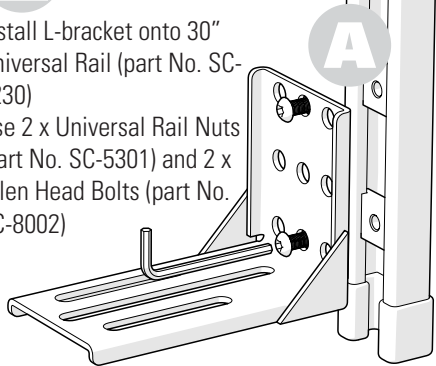

Install Butt Plate (No. SC-1900) on L-bracket (part No. SC-9903) as illustrated, using allen screws and metal screws provided with the butt plate.

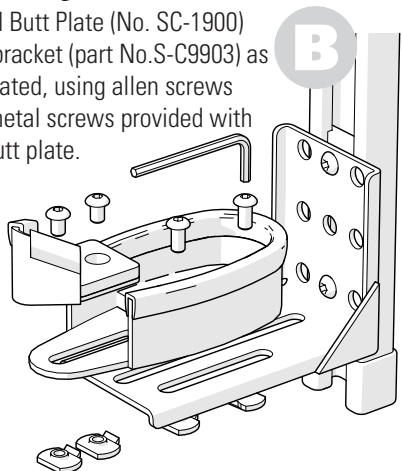

3 Adjust the parts

Slightly tighten all bolts and screws so you can still move parts around. Put your actual weapon in the gun lock and butt plate and position your whole assembly at your intended location. Adjust hinge height/angle and butt plate position until your weapon is properly lined up.

Parts of the weapon may interfere with parts of Mounting Hinge (No. SC-9302). In this case turn the hinge around 180 degrees.

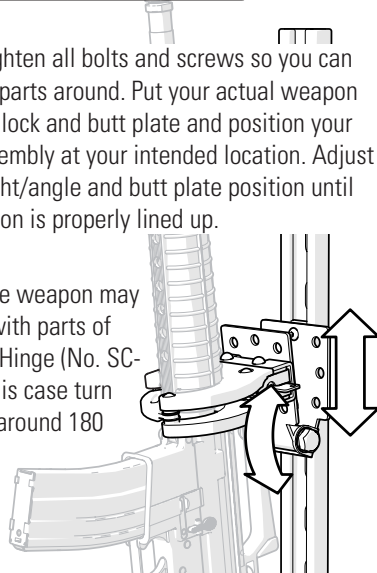

Warning: If you close the ratchet arm tightly on your firearm, you will have to press or tap the outer rubber surface of the ratchet arm when deploying the firearm. This will release the backup safety inside the gun lock, releasing your weapon.

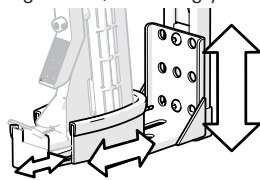

4 Mark the holes

Mark screw locations on wall/floor. Check back side of wall for fuel or electric lines.

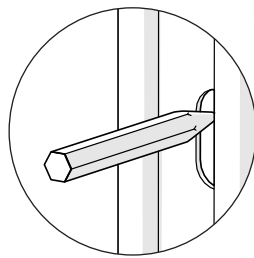

5 Drill and install

Drill your holes and install assembly.

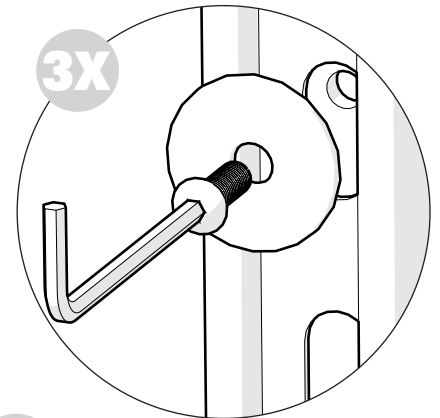

6 Tighten the screws

Place your weapon in the setup, test and retest your installation by repeatedly inserting and removing the weapon from the assembly. When satisfied, tighten all screws and test again.

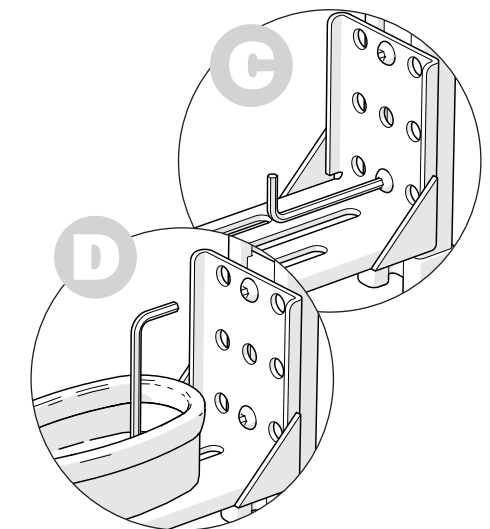
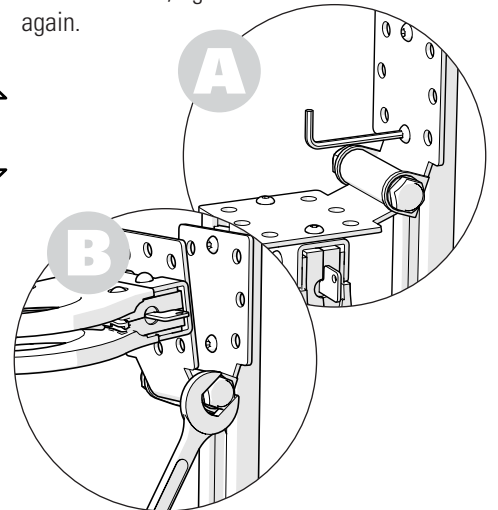

How to use the SC-5301 Universal Rail Nuts

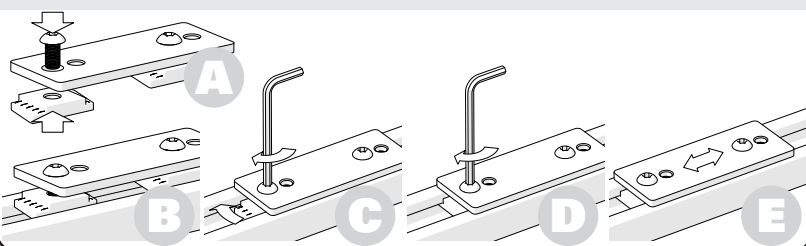

Universal Rail Pump Shotgun & SC-5 Gun Rack **SC-920-D-1-5**

Important

Should you have any problem installing or using Santa Cruz products, we are here to help you every step of the way. Just give us a call at our toll free number (800) 847-5428 and we will be glad to help you with the installation, special part request or any other way you might need assistance.

WARNING! SAFETY FIRST!
Gun Lock Safety Precautions



NOTE:

Santa Cruz Gunlocks, LLC (SCG) gun racks and gun locks are intended for temporary, secure storage of firearms. They are not substitutes for a permanent storage enclosure and only act as limited theft deterrents. And they will not prevent accidental discharge/firing of a chambered round.

To properly and safely use the SCG gun rack and/or gun lock:

- Do not use if your firearm does not fit the SCG gun rack and/or gun lock
- Never chamber a round while using a SCG gun rack and/or gun lock
- It is the responsibility of the user to operate the SCG gun rack and/or gun lock properly and safely

Santa Cruz Gunlocks, LLC (SCG) warrants this product to be free of defects in material and workmanship under normal use for one year from the date of purchase.

SCG makes no other express or implied warranties of the product. The purchaser's sole and exclusive remedy in the unlikely event of breach of warranty is expressly limited to, at SCG's election, repair, refurbishment, or replacement of the defective product with the same version or an upgrade or, if replacement is not possible, a refund of the purchase price.

Shipping cost to SCG must be paid by the user and SCG will pay return shipping charges. Repair parts and replacement products will be provided on an exchange base only and will be either reconditioned or new. This limited warranty does not cover damage to the product resulting from accident, disaster, misuse, abuse, negligence, improper installation or modification or repair of the product other than by SCG. Limited warranty service may be obtained by returning the product to SCG. THIS LIMITED WARRANTY IS IN LIEU OF ALL OTHER WARRANTIES, EXPRESS OR IMPLIED, INCLUDING, BUT NOT LIMITED TO, THE IMPLIED WARRANTIES OF MERCHANTABILITY AND FITNESS FOR A PARTICULAR PURPOSE. Some states, do not allow the exclusion of implied warranties, so their exclusion above may not apply to you.

LIMITATION OF LIABILITY

NEITHER SCG NOR ITS AUTHORIZED DEALER(S) SHALL BE LIABLE FOR ANY DIRECT, INDIRECT, INCIDENTAL, SPECIAL, OR CONSEQUENTIAL DAMAGES, WHETHER IN AN ACTION IN CONTRACT OR TORT (INCLUDING NEGLIGENCE AND STRICT LIABILITY), SUCH AS, BUT NOT LIMITED TO, LOSS OF ANTICIPATED PROFITS OR BENEFITS RESULTING FROM THE USE OR NOT USE OF THE PRODUCT OR ANY BREACH OF ANY WARRANTY, EVEN IF SCG OR ITS AUTHORIZED REPRESENTATIVE HAS BEEN ADVISED OF THE POSSIBILITY OF SUCH DAMAGES. IN NO EVENT WILL SCG OR ITS AUTHORIZED REPRESENTATIVES' LIABILITY EXCEED THE PRICE PAID FOR THE PRODUCT.

Tamper resistant hardware (optional)

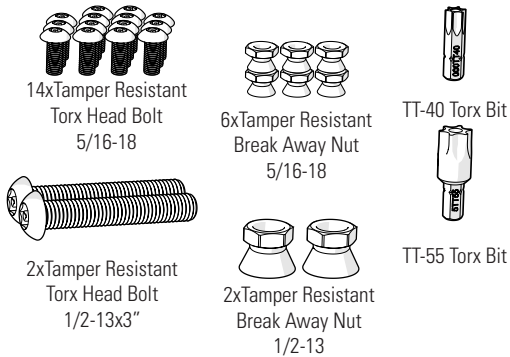

Tools needed for installation

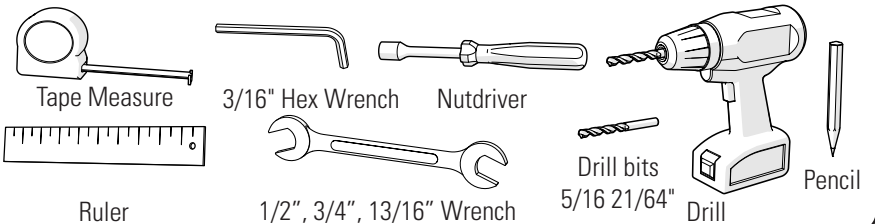

Note: